

Additel 875 Series Dry Well Calibrators



- Three models ranging from -40°C to 660°C
- Portable, rugged, and quick to temperature
- Metrology-level performance in stability, uniformity, accuracy and loading effect
- Dual-zone control
- Full HART field communicator
- Process calibrator option provides a multi-channel readout for a reference thermometer, RTDs and TCs, task documentation , and HART communication
- Color touch screen display
- Choose your own range option
- Set point control by reference
- Self-calibration feature

OVERVIEW

If you are serious about portable temperature calibration tools, then you know a good dry well calibrator is more than just a stable heat source. The Additel 875 Series Dry Well Calibrators combine excellent performance in stability, radial and axial uniformity, and loading with speed, ruggedness and portability. But we don't stop there! The Process Calibrator option adds the capabilities of a three-channel thermometer readout and a documenting process calibrator. We've also incorporated a unique option to select your own temperature range within the range of the model selected. We're calling this the CYOR option or Choose Your Own Range option. When you purchase the CYOR option, you pick the upper and lower temperature range needed and we calibrate and optimize the dry well's performance over your selected range. Each unit has a color touch screen display, dual-zone control, and much more. You are just going to love these new dry wells!



Process Calibrator Option

Each model offer has a Process Calibrator (PC) option. This process calibrator option combines the many features found in a fully functional HART documenting process calibrator with the temperature dry well. This option includes the ability to measure a reference PRT and two devices under test channels which can measure, mA, voltage, switch, RTD or thermocouple. In addition to these measurement functions, this calibrator has full documenting capability of creating tasks, saving as found and as left results, as well as reading, configuring and calibrating HART capable transmitters. The snap shot feature allows you to capture all information displayed on the screen with the push of a button. This optional add-on allows for data logging of all channels on an auto step function and a ramp function. By utilizing the reference PRT, you can select to control to the dry well set point using the internal sensor or the external reference PRT.

Self-Calibration

We believe using an external reference probe as your standard is the best way to perform your temperature calibration. But we also recognize this method is not always necessary or convenient and depending on the application, using the internal control sensor would be preferred. Traditionally, the internal control sensor has a wide accuracy which can largely be contributed to its long-term drift. We've built-in a self-calibration feature allowing you to run an automated calibration of the internal control sensor using your external reference. With literally a few selections the calibration will run automatically giving you a fresh, traceable calibration of the control sensor which will improve its accuracy as you will not have to account for its long term drift when used as the reference.

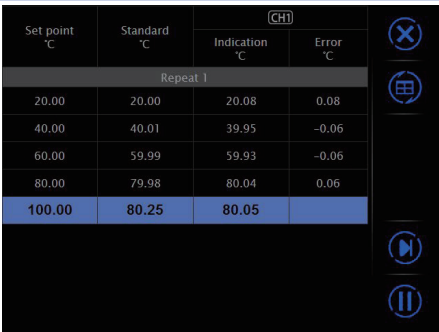
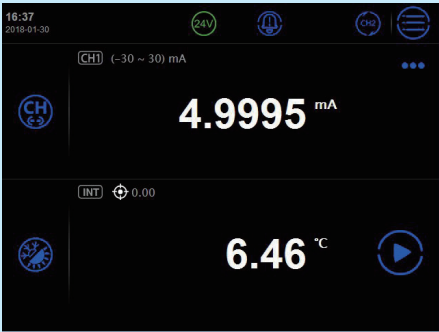
FEATURES

Specification	Display																												
Task	 <table border="1"> <thead> <tr> <th>Set point °C</th> <th>Standard °C</th> <th>Indication °C</th> <th>Error °C</th> </tr> </thead> <tbody> <tr> <td colspan="4">Repeat 1</td> </tr> <tr> <td>20.00</td> <td>20.00</td> <td>20.08</td> <td>0.08</td> </tr> <tr> <td>40.00</td> <td>40.01</td> <td>39.95</td> <td>-0.06</td> </tr> <tr> <td>60.00</td> <td>59.99</td> <td>59.93</td> <td>-0.06</td> </tr> <tr> <td>80.00</td> <td>79.98</td> <td>80.04</td> <td>0.06</td> </tr> <tr> <td>100.00</td> <td>80.25</td> <td>80.05</td> <td></td> </tr> </tbody> </table>	Set point °C	Standard °C	Indication °C	Error °C	Repeat 1				20.00	20.00	20.08	0.08	40.00	40.01	39.95	-0.06	60.00	59.99	59.93	-0.06	80.00	79.98	80.04	0.06	100.00	80.25	80.05	
Set point °C	Standard °C	Indication °C	Error °C																										
Repeat 1																													
20.00	20.00	20.08	0.08																										
40.00	40.01	39.95	-0.06																										
60.00	59.99	59.93	-0.06																										
80.00	79.98	80.04	0.06																										
100.00	80.25	80.05																											
mA Measurement	 <p>18:37 2018-01-30</p> <p>CH1 (-30 ~ 30) mA</p> <p>4.9995 mA</p> <p>INT 0.00</p> <p>6.46 °C</p>																												
V Measurement	 <p>18:38 2018-01-30</p> <p>CH1 (-30 ~ 30)V</p> <p>1.0000 V</p> <p>INT 0.00</p> <p>12.59 °C</p>																												



Non-PC version PC version

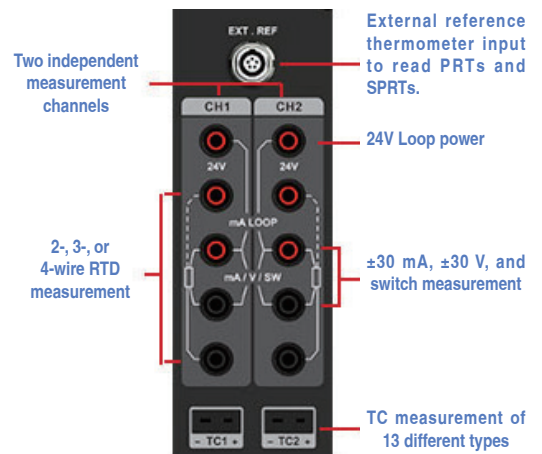

Process Calibrator
Optional Electronics

FEATURES

Specification	Display 1	Display 2
Auto Step		
Remote Control		
Data Logging		
Stability Indicator		
Connection Instruction		

APPLICATIONS



Metrology Made Simple

Specification	Display	Application
PRT Test (External Reference)		
RTD Test		
TC Test		
Transmitter Test		
Switch Test		

SPECIFICATIONS

Base Unit Dry Well Specifications

Specification	875-155	875-350	875-660
Temperature Range at 23° C	-40°C to 155°C	33°C to 350°C	33°C to 660°C
Display Accuracy	± 0.18°C at Full Range	± 0.2°C at Full Range	± 0.3°C at 33°C
			± 0.3°C at 420°C
			± 0.5°C at 660°C
Stability (30 min)	± 0.01°C at Full Range	± 0.02°C at Full Range	± 0.02°C at 33°C
			± 0.03°C at 50°C
			± 0.04°C at 420°C
			± 0.04°C at 660°C
Axial Uniformity at 60 mm (2.4 in)	± 0.07°C at Full Range	± 0.04°C at 33°C	± 0.05°C at 33°C
		± 0.1°C at 200°C	± 0.3°C at 420°C
		± 0.2°C at 350°C	± 0.5°C at 660°C
Radial Uniformity	± 0.01°C at Full Range	± 0.01°C at 33°C	± 0.02°C at 33°C
		± 0.015°C at 200°C	± 0.05°C at 420°C
		± 0.02°C at 350°C	± 0.1°C at 660°C
Loading Effect	± 0.1°C (Display Sensor)	± 0.15°C (Display Sensor)	± 0.15°C (Display Sensor)
	± 0.02°C (External Sensor)	± 0.015°C (External Sensor)	± 0.035°C (External Sensor)
Hysteresis (Display Sensor)	0.025°C	0.03°C	0.1°C
Environmental Conditions	8°C to 38°C guaranteed accuracy		
	0°C to 50°C, 0% to 90% RH non-condensing, 3000 M altitude for normal operation		
Storage Conditions	-20°C to 60°C		
Immersion Depth	145 mm (5.70 in)	150 mm (5.90 in)	
Insert OD	25.8 mm (1.02 in)	24.8 mm (0.98 in)	
Heating Time	13 min: -40°C to 155°C	10 min: 33°C to 350°C	15 min: 33°C to 660°C
	5 min: -40°C to 23°C		
	8 min: 23°C to 155°C		
Cooling Time	28 min: 155°C to -40°C	15 min: 350°C to 100°C	23 min: 660°C to 100°C
	8 min: 155°C to 23°C	10 min: 100°C to 50°C	12 min: 100°C to 50°C
	20 min: 23°C to -40°C	10 min: 50°C to 33°C	12 min: 50°C to 33°C
Typical Time to Stability	10 min		
Resolution	0.01°C		
Units	°C, °F, and K		
Display	6.5 in (165 mm) color touch screen		
Size (H x W x D)	320 x 170 x 330 mm (12.6 x 6.7 x 13.0 in)		
Weight	9.9 kg (21.8 lbs)	8.6 kg (18.9 lbs)	
Power Requirements	90-254 VAC, 45-65 Hz, 580 W	90-254 VAC, 45-65 Hz, 1200 W	
Mechanical Testing	Vibration: 2 g (10-500 Hz), 30 min for 2 sides		
	Impact: 4 g three times		
	Drop test: 500 mm (19.6 in)		
Communication	USB A, USB B, RJ45, WiFi, Bluetooth		
Localization	English, Chinese, Japanese, Russian, German, French, Italian, and Spanish		
Warranty	1 year		



Metrology Made Simple

Input Specifications (Process Calibrator [PC] Option)

Specification	Description	
Readout Accuracy for 100 ohm PRT (Probe Accuracy Not Included)	± 0.009°C at -40°C	
	± 0.010°C at 0°C	
	± 0.012°C at 50°C	
	± 0.017°C at 155°C	
	± 0.019°C at 200°C	
	± 0.026°C at 350°C	
	± 0.030°C at 420°C	
	± 0.042°C at 660°C	
Readout Resolution	0.5 mΩ	
Reference Resistance Range	0 Ω to 400 Ω	
Reference Resistance Accuracy	0 Ω to 50 Ω: ± 0.002 Ω	
	50 Ω to 400 Ω: ± 40 ppm RD	
Reference Characterizations	ITS-90, CVD, IEC-751, Resistance	
Reference Measurement Capability	4-wire PRT	
Reference Probe Connection	6-pin lemo smart connector	
RTD Channels	2	
RTD Measurement Accuracy (excl sensor) Compliance	0 Ω to 25 Ω: ± 0.002 Ω	
	25 Ω to 400 Ω: ± 0.008% RD	
	400 Ω to 4K Ω: ± 0.008% RD	
RTD Measurement Resolution	0 Ω to 400 Ω: 1 mΩ	
	400 Ω to 4K Ω: 0.01 Ω	
RTD Measurement Resistance Range	0 Ω to 4K Ω	
RTD Characterizations	PT10, PT25, PT50, PT100, PT200, PT500, PT1000, CU10, CU50, CU100, NI100, NI120	
RTD Connection	Four 4 mm input jacks	
RTD Channels	2 channels. Both accept 2, 3, or 4-wire RTDs	
TC Channel	2	
TC Measurement Channels	Mini TC terminals: Accepting S, R, K, B, N, E, J, T, C, D, G, L, and U	
TC Measurement Accuracy (excl sensor)	Type K: ± 0.13°C at 0°C ± 0.16°C at 155°C ± 0.19°C at 350°C ± 0.25°C at 660°C	
	TC Range	-75 mV to 75 mV
	TC Resolution	0.0001 mV, Input Impedance >100 MΩ
	TC Voltage Accuracy	0.02% RD + 5 μV
Internal CJC Accuracy	± 0.35°C (ambient from 0°C to 50°C)	
Current Range	-30 mA to 30 mA	
Current Accuracy	0.02% RD + 2 μA	
Current Resolution	0.0001 mA, Input Impedance: < 10 Ω	

Specification	Description
Voltage Ranges	-12 V to 12 V and -30 V to 30 V
Voltage Accuracy	±0.02% RD + 2 mV
Voltage Resolution	0.001 V; Input impedance: > 1MΩ
Switch Test	Mechanical or Electrical
DC 24V Output	24V ±10%, MAX60 mA
Hart Communicator	Read, configure and calibrate HART devices - DD files updated periodically Optional - (order ADT875PC)
Documentation	Up to 1,000 tasks which store up to 10 results each containing as found and as left data. Snap shot feature allows for screen captures. Records auto step and ramp functions.
Temperature Coefficient 0° C to 8° C and 38° C to 50° C	ADT875 (PC)-155: ±0.005°C/°C
	ADT875 (PC)-350/660: ±0.01°C/°C
	Ref Readout: ±5 ppm FS/°C
	RTD Readouts: ±2 ppm FS/°C
	TC Readouts: ±5 ppm FS/°C
	Current: ±5 ppm FS/°C
	Voltage: ±5 ppm FS/°C

TC Measurement Specification and Calculation (Process Calibrator [PC] Option)

TC Type	Temperature (°C)	Error (°C) ^[1]	TC Type	Temperature (°C)	Error (°C) ^[1]
B	250	±2	L	-40	±0.1
	350	±1.44		0	±0.1
	660	±0.84		155	±0.12
C	0	±0.38	N	350	±0.16
	155	±0.34		660	±0.21
	350	±0.33		-40	±0.2
	660	±0.38		0	±0.2
D	0	±0.52	R	155	±0.19
	155	±0.37		350	±0.2
	350	±0.33		660	±0.24
E	660	±0.36	S	-40	±1.23
	-40	±0.09		0	±0.95
	0	±0.09		155	±0.63
	155	±0.1		350	±0.56
G	350	±0.13	T	660	±0.54
	660	±0.19		-40	±1.16
	0	±3.85		0	±0.93
	155	±0.71		155	±0.65
J	350	±0.43	U	350	±0.6
	660	±0.36		660	±0.6
	-40	±0.1		-40	±0.14
	0	±0.1		0	±0.13
K	155	±0.12	T	155	±0.13
	350	±0.16		350	±0.15
	660	±0.21		400	±0.15
	-40	±0.13		-40	±0.14
	0	±0.13		0	±0.13
K	155	±0.15	U	155	±0.13
	350	±0.18		350	±0.14
	660	±0.24		600	±0.17



[1] Excluding cold junction compensation errors.

Ordering Information

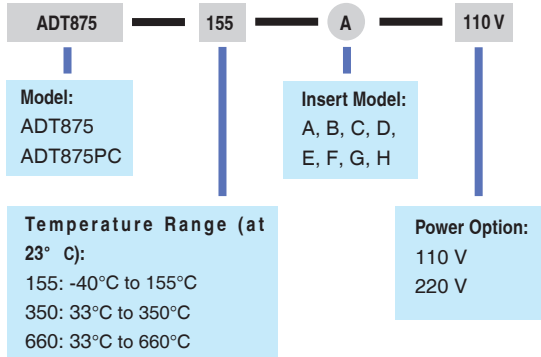







Model Number











CYOR Option (Choose Your Own Range)



Optional Accessories		
Model	Description	Picture
9875-155-CYOR	Range selection for ADT875-155 Dry Well Calibrator, Customize Range	
9875-350-CYOR	Range selection for ADT875-350 Dry Well Calibrator, Customize Range	
9875-660-CYOR	Range selection for ADT875-660 Dry Well Calibrator, Customize Range	

Accessories

Standard Accessories		
Model	Quantity	Picture
Dry well and selected insert	1 pc.	
Power cable	1 pc.	
USB Cable	1 pc.	
Insert removal tool	1 pc.	
Thermal Shield (ADT875/PC-350/660 only)	1 pc.	
Silica gel plug (ADT875/PC-155 only)	1 set (3 pcs.)	
Insulation plug (ADT875/PC-155 only)	1 pc.	
Test leads (ADT875PC only)	2 sets (4 pcs.)	
ISO 17025 Accredited calibration	1 pc.	

Optional Accessories		
Model	Description	Picture
9915-875	Carry Case for ADT875-155/350/660 with wheels	
ADT110-875-X-INSERT-X	Insert for ADT875, see insert ordering information on the next page	
AM17XX-12-ADT	Secondary PRT with dry well connector, see PRT information on the next page	
AM17XX-BEND-ADT	Bend Secondary PRT with dry well connector, see PRT information on the next page	
9070	Smart connector for reference PRT used with ADT875 Dry Well Calibrator	
9071	Connector Adapter from smart connector to 4-wire with gold-plated spades for ADT875 Dry Well Calibrator	
9072	Smart connector with clamps for reference PRT used with ADT875 Dry Well Calibrator	
9080	Cable Kit (includes TC plug, compensation cable, S,R,,K,J,T,E,N)	
ADT110-875-L-SHRT-IKIT	Short probe temperature calibration kit (More details, see Short Probe Temperature Calibration Kit Datasheet)	

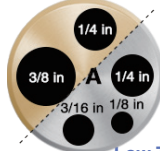
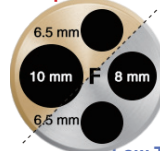
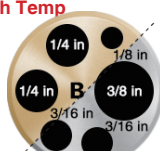
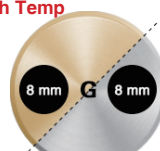
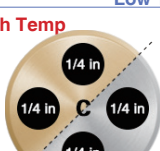
Insert Information

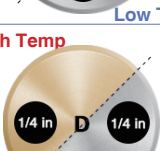
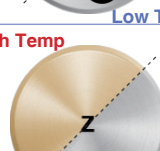
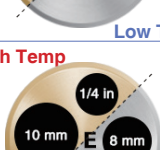
Insert Information			
Model	Specification	Model	Specification
A	<p>High Temp</p>  <p>Low Temp</p>	F	<p>High Temp</p>  <p>Low Temp</p>
B	<p>High Temp</p>  <p>Low Temp</p>	G	<p>High Temp</p>  <p>Low Temp</p>
C	<p>High Temp</p>  <p>Low Temp</p>	H	<p>High Temp</p>  <p>Low Temp</p>
D	<p>High Temp</p>  <p>Low Temp</p>	Z	<p>High Temp</p>  <p>Low Temp</p>
E	<p>High Temp</p>  <p>Low Temp</p>	<p>* Updated insert information at www.additel.com</p>	

Insert Ordering Information

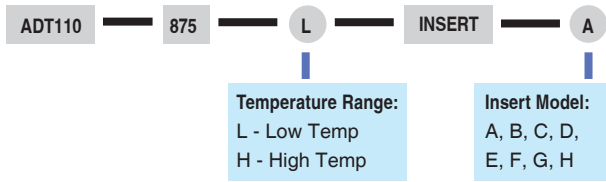

Secondary PRT Ordering Information

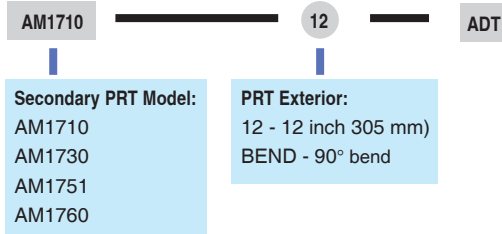

Secondary PRT Information

AM17XX-12-ADT

AM17XX-BEND-ADT

Specification	AM1710 Series	AM1730 Series	AM1751 Series	AM1760 Series
Temperature Range ^[3]	-40°C to 160°C	-200°C to 420°C	-200°C to 670°C	-200°C to 670°C
Resistance at 0° C	Nominal 100Ω			
Temperature Coefficient	0.003925 Ω / Ω / °C			
Calibrated Accuracy (k=2) ^{[2][3]}	±0.025°C at -40°C ±0.015°C at 0.01°C ±0.025°C at 160°C	±0.025°C at -40°C ±0.015°C at 0.01°C ±0.035°C at 420°C	±0.025°C at -40°C ±0.015°C at 0.01°C ±0.035°C at 420°C ±0.05°C at 661°C	±0.010°C at -196°C ±0.006°C at 0.01°C ±0.015°C at 420°C ±0.025°C at 661°C
Drift	±0.01°C at TPW after 100 hours at 160°C	±0.01°C at TPW after 100 hours at 420°C	±0.01°C at TPW after 100 hours at 661°C	±0.004°C at TPW after 100 hours at 661°C
Short Term Stability	±0.007°C			±0.002°C
Thermal Shock	±0.005°C after (10) thermal cycles from minimum to maximum temperatures			±0.002°C after (10) thermal cycles from minimum to maximum temperatures
Hysteresis	<=0.005°C			<=0.001°C
Self-heating	50 mW/°C			0.0015°C at 0.5mA
Response Time	9 seconds for 63% response to step change in water moving at 3 feet per second			
Measurement Current	0.5 mA or 1 mA			
Sensor Length	32 mm			42 mm
Sensor Location	5 mm from tip			
Insulation Resistance	>1000 MΩ at room temperature			
Sheath Material	Stainless Steel	Inconel™		
Dimension	AM1710-12-ADT 0.25 in dia X 12 in (6.35 mm X 305 mm)	AM1730-12-ADT 0.25 in dia X 12 in (6.35 mm X 305 mm)	AM1751-12-ADT 0.25 in dia X 12 in (6.35 mm X 305 mm)	AM1760-12-ADT 0.25 in dia X 12 in (6.35 mm X 305 mm)
	AM1710-BEND-ADT 0.25 in dia X 12 in (6.35 mm X 305 mm), 90° bend at 7.4 inch (190 mm) from probe end	AM1730-BEND-ADT 0.25 in dia X 12 in (6.35 mm X 305 mm), 90° bend at 9.6 inch (245 mm) from probe end	AM1751-BEND-ADT 0.25 in dia X 12 in (6.35 mm X 305 mm), 90° bend at 9.6 inch (245 mm) from probe end	AM1760-BEND-ADT 0.25 in dia X 12 in (6.35 mm X 305 mm), 90° bend at 9.6 inch (245 mm) from probe end
External Leads	Teflon™ –insulated copper wire, 4 leads, 0.8 meters			
Handle Dimension	15 mm (OD) x 65 mm (L)			
Handle Temperature Range ^[1]	-50°C to 160°C	-50°C to 180°C		
Calibration	ISO 17025 accredited calibration			

[1] Handle temperatures outside this range will cause damage to the probe.

[2] Includes calibration and 100 hour drift.

[3] Probe calibration ranges may differ from probe temperature ranges (see Calibrated Accuracy for calibration ranges).

* PRT Information from www.accumac.com